

---

# WS2811

## Signal line 256 Gray level 3 channel Constant current LED driver IC

---

### Feature

- Output port compression 12V.
- Built-in voltage-regulator tube, only a resistance needed to add to IC VDD feet when under 24V power supply.
- 256 Gray-scale adjustable and scan frequency is more than **2KHz**.
- Built in signal reshaping circuit, to ensure waveform distortion do not accumulate after wave reshaping to the next driver
- Built-in electrify reset circuit and power-down reset circuit.
- Cascading port transmission signal by single line.
- Any two point the distance less than 5 Meters transmission signal without any increase circuit.
- When the refresh rate is 30fps, the cascade number is at least 1024 pixels.
- Send data at speed of 800Kbps.

### Applications

- LED decorative lighting.
- Indoor/outdoor LED video or irregular screen.

### General description

The WS2811 is 3 output channels special for LED driver circuit. Its internal includes intelligent digital port data latch and signal reshaping amplification drive circuit. Also include a precision internal oscillator and a 12V voltage programmable constant current output drive. In the purpose of reduce power supply ripple, the 3 output channels designed to delay turn-on function.

IC use single NZR communication mode. After the chip power-on reset, the DIN port receive data from controller, the first IC collect initial 24bit data then sent to the internal data latch, the other data which reshaping by the internal signal reshaping amplification circuit sent to the next cascade IC through the DO port. After transmission for each chip, the signal to reduce 24bit. IC adopt auto reshaping transmit technology, making the chip cascade number is not limited the signal transmission, only depend on the speed of signal transmission.

The data latch of IC depend on the received 24bit data produce different duty ratio signal at OTR, OUTG, OUTB port. All chip synchronous send the received data to each segment when the DIN port input a reset signal. It will receive new data again After the reset signal finished. Before a new reset signal received, the control signal of OTR ,OUTG, OUTB port unchanged. IC sent PWM data that received justly to OTR, OUTG, OUTB port, after receive a low voltage reset signal the time retain over **280μs**.

We offer TWO package SOP8 and MSOP8.

# WS2811

## Signal line 256 Gray level 3 channel Constant current LED driver IC

### PIN configuration

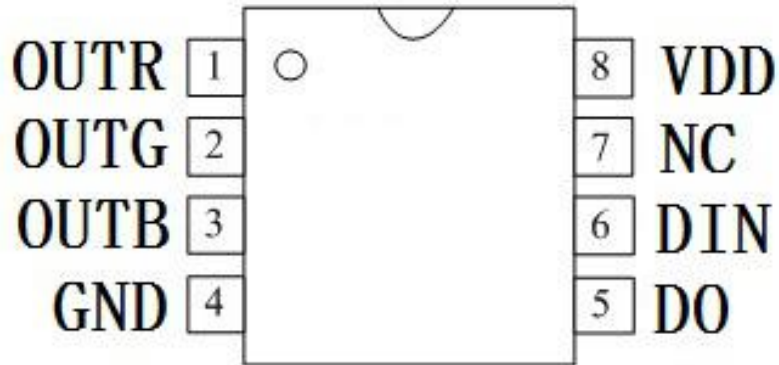

### PIN function

NO.	Symbol	PIN	Function description
1	OUTR	LED Driver Output	Output of RED PWM control
2	OUTG	LED Driver Output	Output of GREEN PWM control
3	OUTB	LED Driver Output	Output of BLUE PWM control
4	GND	Ground	Data & Power Grounding
5	DO	DO	Data Output
6	DIN	Data Input	Control data input
7	NC	NC	NC
8	VDD	Power Voltage	IC power supply

### Absolute Maximum Ratings ( $T_A=25^{\circ}\text{C}$ , $V_{SS}=0\text{V}$ , unless otherwise noted.)

Parameter	Symbol	Ratings	Unit
Power Supply Voltage	$V_{DD}$	+3.5~+5.3	V
Logical Input Voltage	$V_I$	$V_{DD}-0.5 \sim V_{DD}+0.5$	V
Operation Temperature	$T_{opt}$	-25~+85	$^{\circ}\text{C}$
Storage Temperature Range	$T_{stg}$	-40~105	$^{\circ}\text{C}$
R/G/B Channel Output Port Withstand Voltage	$V_{out}$	12	V

Note: If the voltage on the pins exceeds the maximum ratings may cause permanent damage to the device.

# WS2811

## Signal line 256 Gray level 3 channel Constant current LED driver IC

**Electrical Characteristics** ( $T_A=-20\sim+70^{\circ}\text{C}$ ,  $V_{DD}=4.5\sim 5.5\text{V}$ ,  $V_{SS}=0\text{V}$ , unless otherwise specified)

Parameter	Symbol	Conditions	Min	Tpy	Max	Unit
Low voltage output current	$I_{OL}$	ROUT	15.5	16.5	17.5	mA
	$I_{dout}$	$V_o=0.4\text{V}$ , $D_{OUT}$	10	—	—	mA
Input current	$I_I$	$V_I=V_{DD}/V_{SS}$	—	—	$\pm 1$	$\mu\text{A}$
Input voltage level	$V_{IH}$	$D_{IN}$ , SET	$0.7V_{DD}$	—	—	V
	$V_{IL}$	$D_{IN}$ , SET	—	—	$0.3 V_{DD}$	V
Hysteresis voltage	$V_H$	$D_{IN}$ , SET	—	0.35	—	V

**Switching characteristics** ( $T_A=-20\sim+70^{\circ}\text{C}$ ,  $V_{DD}=4.5\sim 5.5\text{V}$ ,  $V_{SS}=0\text{V}$ , unless otherwise specified)

Parameter	Symbol	Condition	Min	Tpy	Max	Unit
Oscillation frequency	$F_{osc}$	—	—	800	—	KHz
Transmission delay time	$T_{PLZ}$	$CL=15\text{pF}$ , $D_{IN}\rightarrow D_{OUT}$ , $RL=10\text{K}\Omega$	—	—	300	ns
Fall time	$T_{THZ}$	$CL=300\text{pF}$ , $OUTR/OUTG/OUTB$	—	—	120	$\mu\text{s}$
Data transmission rate	$F_{MAX}$	Duty ratio 50%	400	—	—	Kbps
Input capacity	$C_I$	—	—	—	15	pF

### Data Transfer Time

T0H	0 code, high voltage time	220ns~380ns
T1H	1 code, high voltage time	580ns~1.6 $\mu\text{s}$
T0L	0 code, low voltage time	580ns~1.6 $\mu\text{s}$
T1L	1 code, low voltage time	220ns~420ns
RES	Frame unit, low voltage time	>280 $\mu\text{s}$

# WS2811

## Signal line 256 Gray level 3 channel Constant current LED driver IC

### Sequence Chart

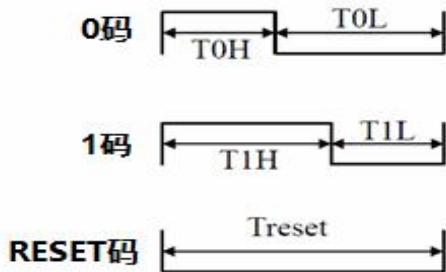

### Cascade Method

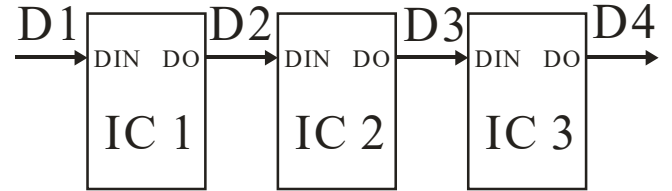

### Data Transmission Method

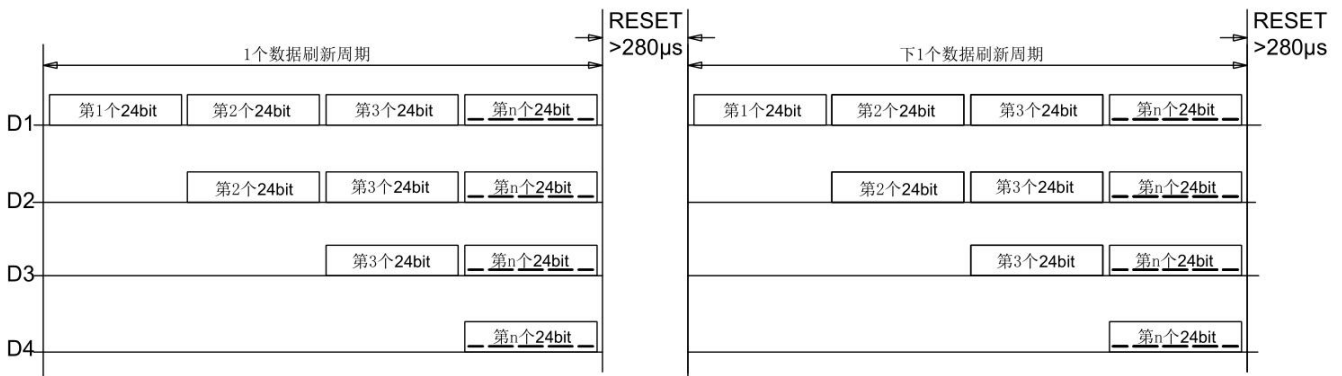

Note: The data of D1 is send by MCU, and D2, D3, D4 through IC internal reshaping amplification to transmit.

### Composition of 24bit Data

R7	R6	R5	R4	R3	R2	R1	R0	G7	G6	G5	G4	G3	G2	G1	G0	B7	B6	B5	B4	B3	B2	B1	B0
----	----	----	----	----	----	----	----	----	----	----	----	----	----	----	----	----	----	----	----	----	----	----	----

Note: Data transmit in order of GRB, high bit data at first.

# WS2811

## Signal line 256 Gray level 3 channel Constant current LED driver IC

### Typical Application Circuit

#### 1. Supply voltage=5V, 1 LED for each channel and Constant Current driving of 16.5mA

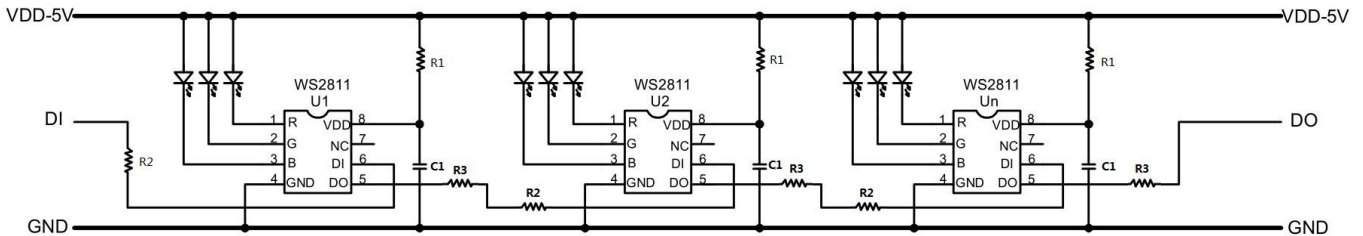

Fig 1

This driving mode use constant current output, the advantage of is the LED can retain luminance and color temperature when the power supply lessen. We require, in order to prevent power spikes phenomenon and power reverse polarity, series with a resistor less than 100ohm connected with the power supply pin(VDD). The capacitance 104 as bypass capacitor. To prevent the reflection and hot-swap protection, we suggest to connect a 33ohm resistor at the data input or output port for impedance.

#### 2. Supply voltage=12V, 3 LED for each channel and Constant Current driving of 16.5mA

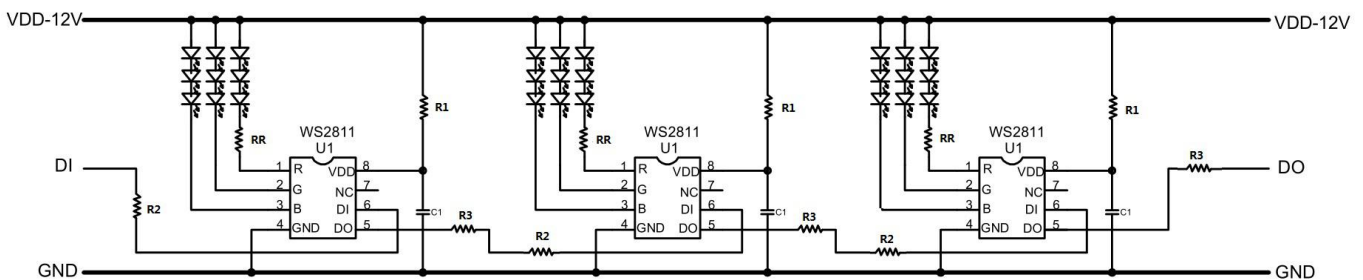

Fig 2

The same as the front mode, it is also use constant current output. In this circuit, R1 is used as the IC internal LDO divider resistance and the value is 2.7K. The capacitance 104 as bypass capacitor. To prevent the reflection and hot-swap protection, we suggest to connect a 33ohm resistor at the data input or output port for impedance. At the OUTR port we should add a divider resistance RR. The value of RR can be derived by the following equation:

$$RR = \frac{12 - 3V_{LEDR}}{16.5} \text{ K}\Omega$$

$V_{LEDR}$  is the red LED forward conduction voltage drop.

### Package information

# WS2811

Signal line 256 Gray level 3 channel  
Constant current LED driver IC

- SOP8 Package

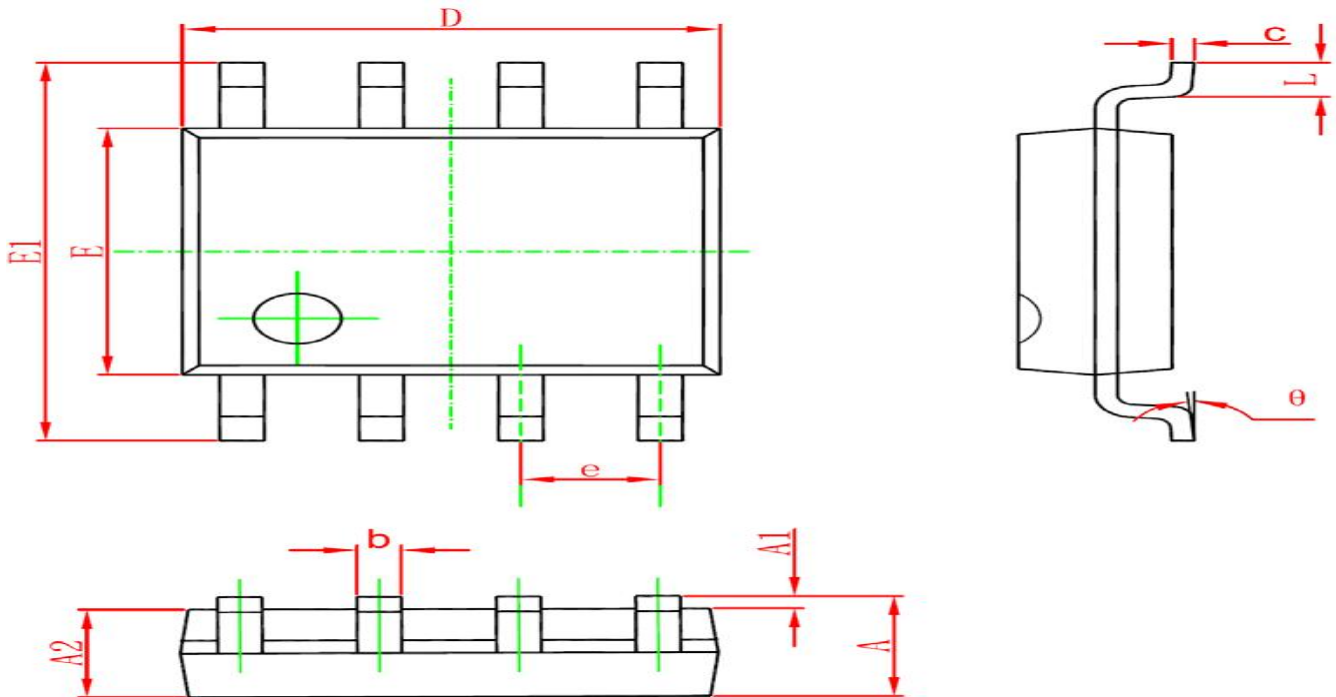

Symbol	Dimensions In Millimeters		Dimensions In Inches	
	Min	Max	Min	Max
A	1.350	1.750	0.053	0.069
A1	0.100	0.250	0.004	0.010
A2	1.350	1.550	0.053	0.061
b	0.330	0.510	0.013	0.020
c	0.170	0.250	0.006	0.010
D	4.700	5.100	0.185	0.200
E	3.800	4.000	0.150	0.157
E1	5.800	6.200	0.228	0.244
e	1.270		0.050	
L	0.400	1.270	0.016	0.050
θ	0°	8°	0°	8°

# WS2811

Signal line 256 Gray level 3 channel  
Constant current LED driver IC

- MSOP8 Package

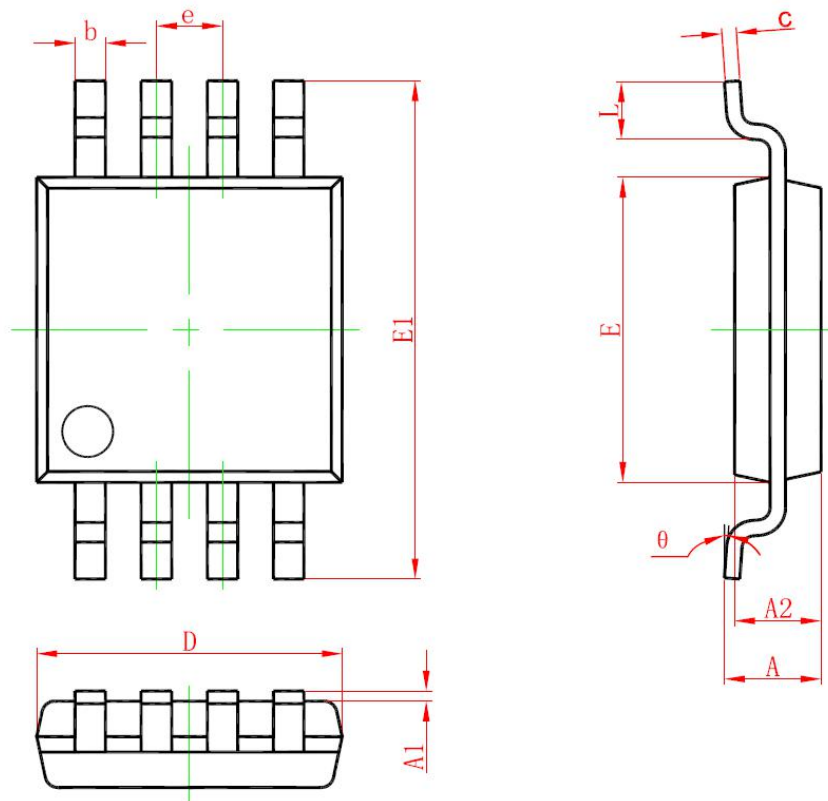

Symbol	Dimensions In Millimeters		Dimensions In Inches	
	Min	Max	Min	Max
A	0.820	1.100	0.032	0.043
A1	0.020	0.150	0.001	0.006
A2	0.750	0.950	0.030	0.037
b	0.250	0.380	0.010	0.015
c	0.090	0.230	0.004	0.009
D	2.900	3.100	0.114	0.122
e	0.650(BSC)		0.026(BSC)	
E	2.900	3.100	0.114	0.122
E1	4.750	5.050	0.187	0.199
L	0.400	0.800	0.016	0.031
θ	0°	6°	0°	6°

---

# WS2811

## Signal line 256 Gray level 3 channel Constant current LED driver IC

---

### Modify Records

Version №	Status Bar	Modify Content Summary	Date	Reviser	Approved
V1.0	N	New	20170523	Shen JinGuo	Yin HuaPing
V1.1	M	Absolute Maximum Ratings	20171009	Shen JinGuo	Yin HuaPing

Remarks: Initial version: V1.0; Version number plus "0.1" after each revision;

Status bar: N--New, A--Add, M--Modify, D--Delete.