

Constant Voltage Triac dimmable driver--80W Series



Features

- Output constant voltage
- Universal AC input/ :180-250VAC
- Built-in active PFC function
- High efficiency :up to 86%
- Protections:short circuit/over loading/over temperature
- Full protection plastic housing
- Easy installation
- Cooling by free air convection
- Work with leading edge and trailing edge TRIAC dimmers
- Strong compatibility, flicker-free dimming
- Suitable for LED lighting and moving sign applications
- Compliance to worldwide safety regulations for lighting

Specification

CE IP20 SELV

Model		KV-12080-TD	KV-24080-TD	KV-36080-TD	KV-48080-TD
output	DC Voltage	12V	24V	36V	48V
	Voltage Tolerance	±0.5V			
	Rated current	6.66A	3.33A	2.22A	1.66A
	Rated power	80W			
input	Voltage Range	180~250VAC (or 90~130VAC)			
	Frequency Range	47~63HZ			
	Power Factor (Typ.)	PF ≥ 0.95/220VAC			
	Efficiency (Typ.)	83%	85%	86%	87%
	AC Current (Typ.)	0.47A	0.45A	0.45A	0.44A
	Leakage current	< 0.70mA/220VAC			
Protection	Short Circuit	Hiccup mode, recovers automatically after fault condition is removed			
	Over Loading	≤ 120%			
	Over temperature	100 °C ± 10 °C (The output voltage will turn off when the temperature is higher then 100 °C ± 10 °C, after the temperature drop off ,it will recovery)			
Environment	Working TEMP.	-40~+60°C			
	Working Humidity	20~90%RH, non-condensing			
	Storage TEM.,Humidity	-40~+80°C, 10~95%RH			
	TEMP.coefficient	±0.03%/°C (0~50°C)			
	Vibration	10~500Hz, 2G 10min./1 cycle,period for 60min. each along X,Y,Z axes			
Safety&EMC	Safety standards	EN61347-1 EN61347-2-13			
	Withstand voltage	I/P-O/P: 3.75KVAC			
	Isolation resistance	I/P-O/P: 100MΩ /500VDC/25°C/70%RH			
	EMC EMISSION	EN55015, EN61000-3-2, 3 (≥ 50%loading)			
	EMC IMMUNITY	EN61000-4-2, 3, 4, 5, 6, 11 (Surge 4KV)			
Others	Net.Weight	1.1 Kg			
	Size	200*70*46mm (L*W*H)			
	packing	329*279*176 10PCS			

Constant Voltage Triac dimmable driver--80W Series

Notes	<p>1. All parameters if NOT specially mentioned are measured at 220VAC input , rated load and 25°C of ambient temperature.</p> <p>2. To extend the driver's using life ,please reduce the loading when start the drivers at lower input voltage.</p> <p>3.Loading should be 60-100%</p>
--------------	---

■80W triac dimmable driver Mechanical Specification

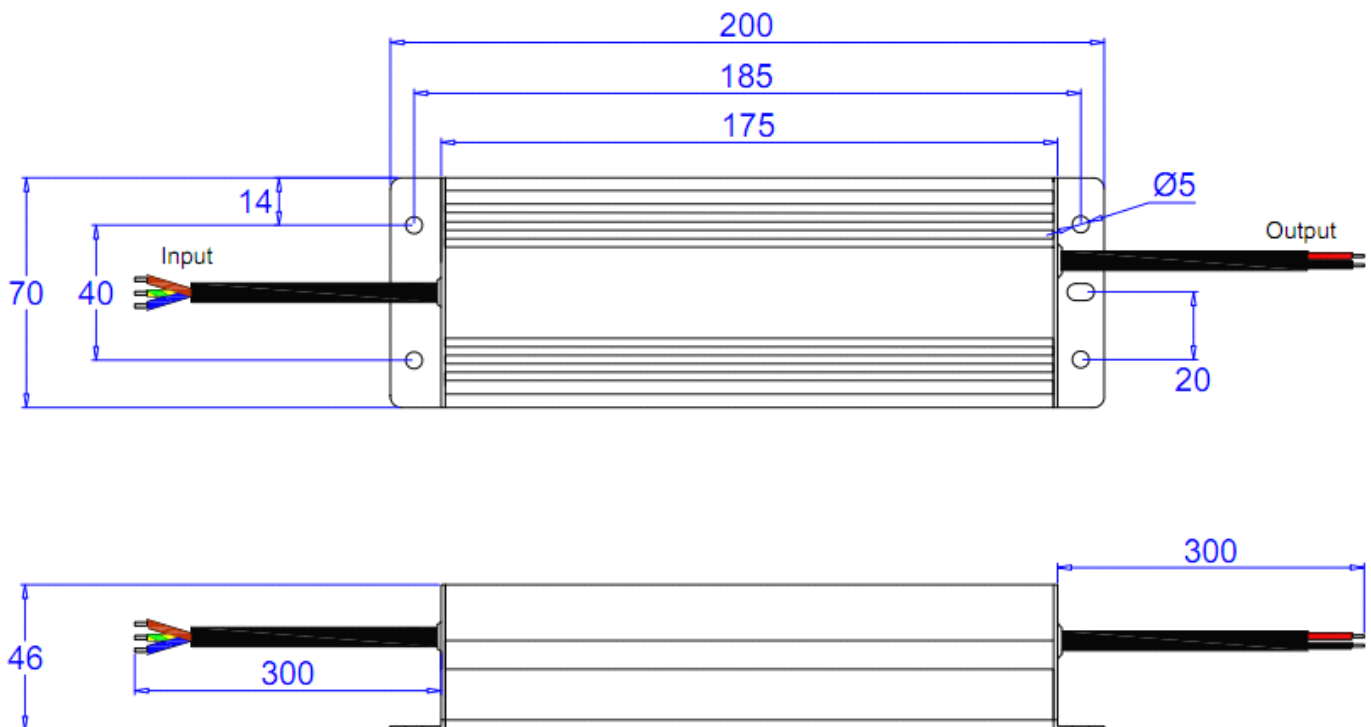

- ※Input Brown with AC (L),Blue with AC(N)
- ※Output Red is (DIM+) ,Black is (DIM-)
- ※Note: Any other requests we can customized.

■Dimming Operation

- ※Output constant current level can be adjusted through input terminal of the AC phase line(L) by connection a triac dimmer.
- ※Compatible with Leading edge or tailing edge triac dimmers.
- ※please try to use the small power dimmer, have access to a wider dimming range, high-power dimmer is difficult to achieve the output current to zero

■Derating Curve

Constant Voltage Triac dimmable driver--80W Series

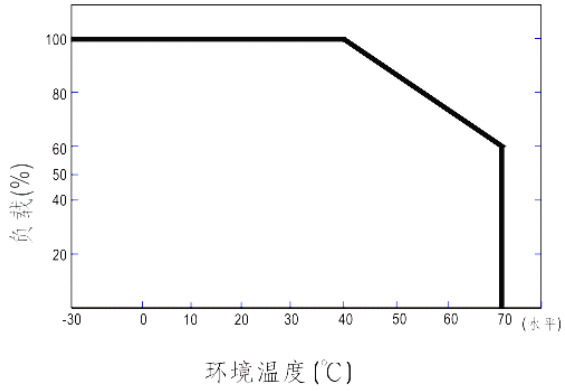

※To extend their life, please refer to the Derating Curve and derate according to the temperature.

■ Connecting Diagram

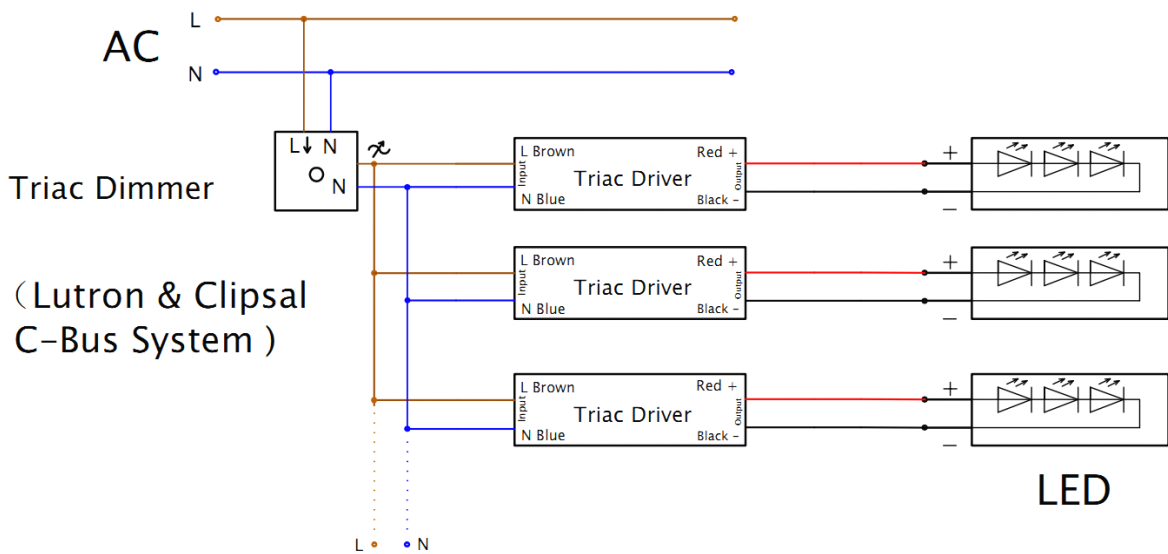
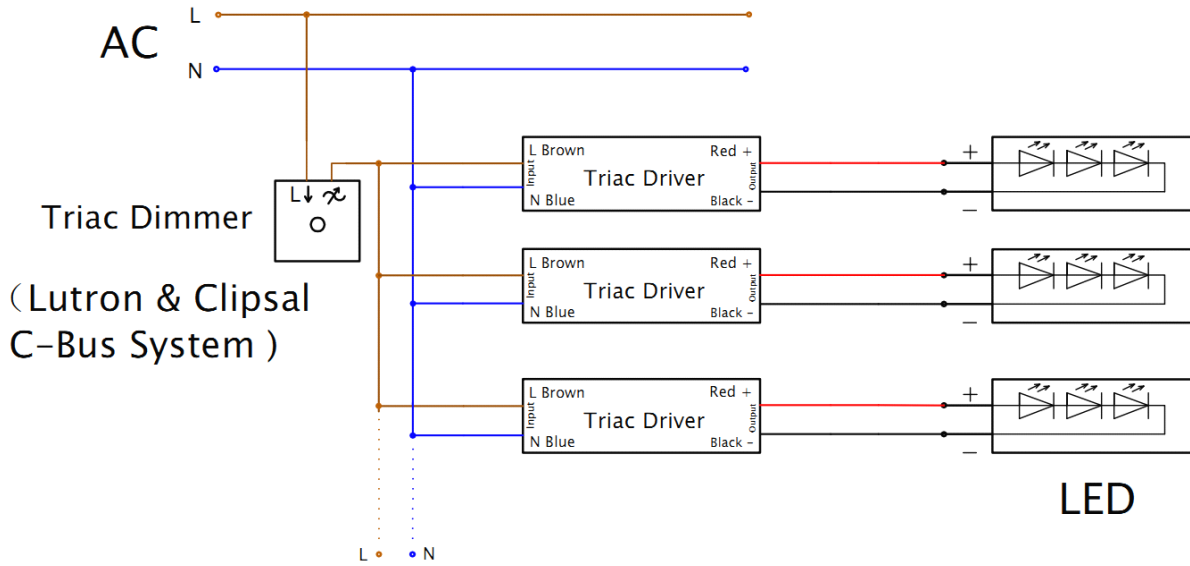

Constant Voltage Triac dimmable driver---80W Series

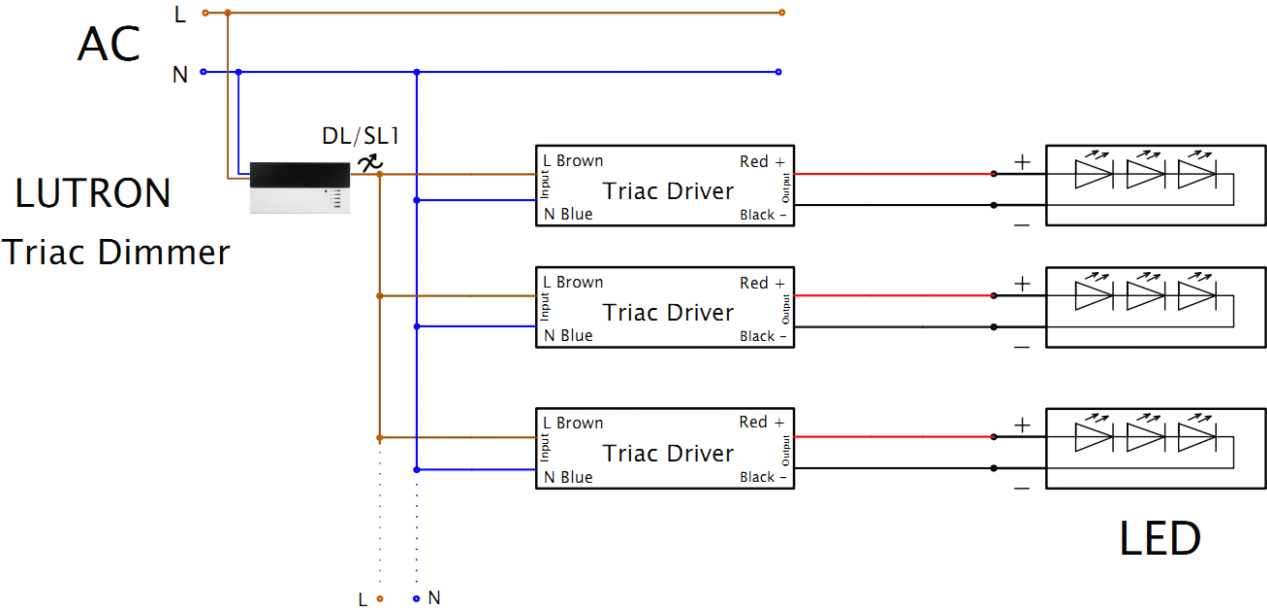

Please visit our website for full Terms and Conditions or contact us for further information